

ORDER # _____
S/N: _____
MAC: _____

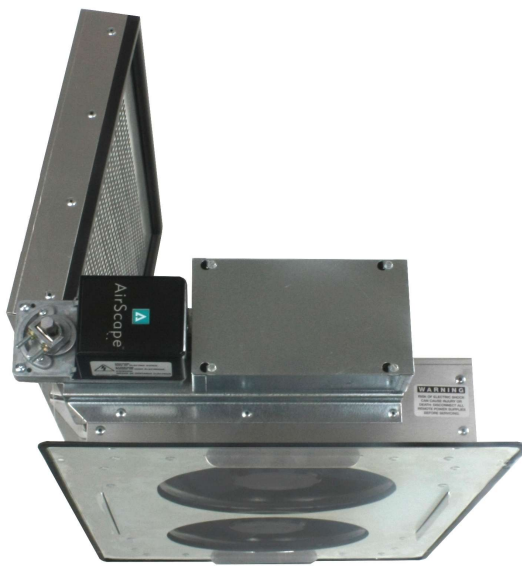

1.0/1.0 XR AND 1.7/1.7 XR WHOLE HOUSE FAN INSTALLATION AND OPERATION MANUAL

© ALL RIGHTS RESERVED | AIRSCAPE INC.



CONGRATULATIONS on your AirScape Whole House Fan purchase. This fan is designed to provide you with quiet, natural, energy-efficient cooling for many years.

Please take a few minutes to read over this manual to make sure you are prepared for the installation. The building owner/occupant should read the "Theory of Operation" insert so that the 1.0/1.7 WHF will be correctly located to maximize effectiveness and efficiency of operation. Attic venting recommendations and calculations are also included in that insert.

If you (or your installer) have any questions regarding the installation, operation, or maintenance of this fan, please call 1.866.448.4187 or email experts@airscapefans.com.

WHAT'S INCLUDED

Prior to beginning installation, please verify that you received all the accessories with the whole house fan. The package should include:

- fan/damper assembly
- grille (including 6 powder coated wood screws)
- adhesive backed foam gasket
- 6 wood screws
- 1 hard wired wall control with timer, 1 wall mounting bracket, 1 red 50' CAT5 cable.

WHAT YOU WILL NEED

- cordless screwdriver w/ Philips head bit
- lumber, matching the dimensions of the attic joists
- high quality latex caulk
- drywall cutting tool

SAFETY INFORMATION



Not So Obvious – Please Read:

- **NEVER** operate your whole house fan without a window or door open.
- This fan is meant for general ventilation. It has **NOT** been designed to vent particle laden and/or explosive mixtures of air.
- If people or animals are expected to be in proximity to an operating whole house fan, there is risk of personal injury from the fan blades. If you feel this situation will occur, **DO NOT** operate the fan without a fan guard. Contact the manufacturer for more information.
- **NEVER** force open the damper doors. Always use the yellow clutch release located on the actuator before attempting to manually open or close damper doors.

UNIT DIMENSIONS

1.0 WHF

Note: The 1.0 Unit needs 20" of total clearance to allow the damper door to open fully.

The electronic components of the 1.0 extend 2" beyond the mounting flange of the unit, making the total overall length 27 1/4"

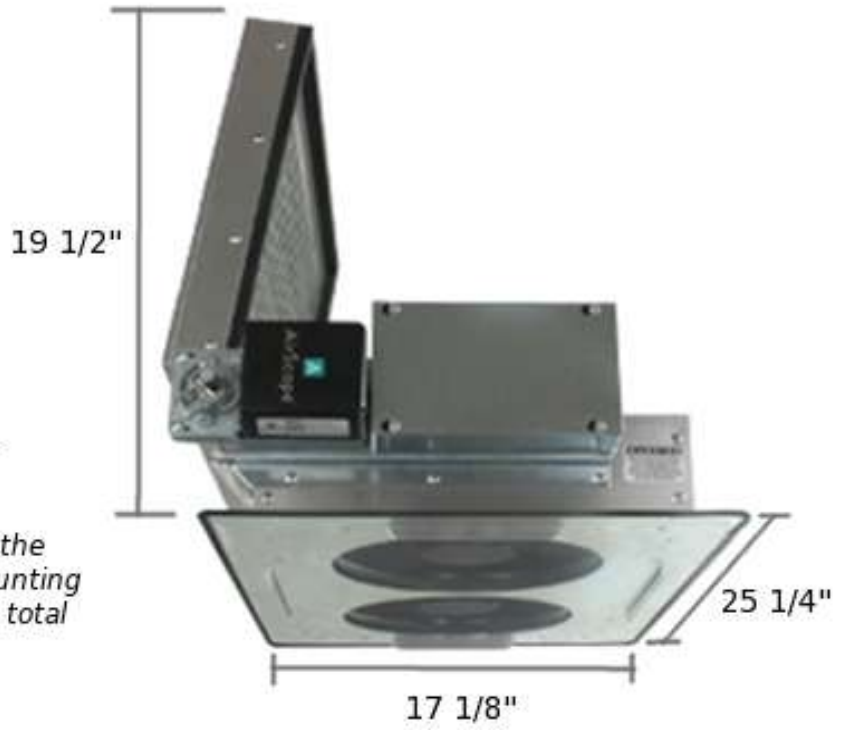

1.7 WHF

The electronic components of the 1.7 extend 2" beyond the length of the mounting flange, making the total overall length 27"

Flange dimensions = 14 1/4" x 22 1/4"

Outer grille dimensions = 16 1/2" x 24 1/2"

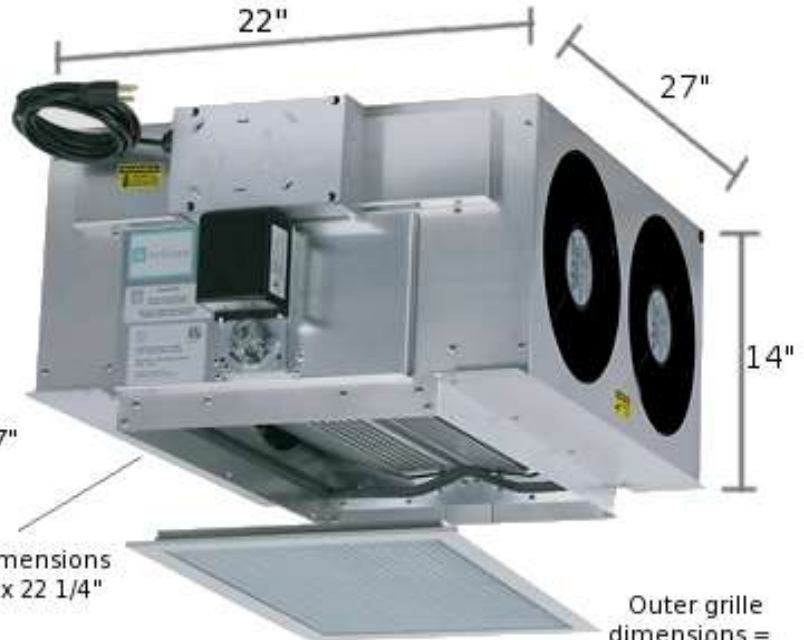

INSTALLATION - CARPENTRY

The 1.7 & 1.0 units have been designed to fit into a 14½" x 22½" wall or ceiling opening. Since most modern houses have been built with either 16" or 24" on-center (o.c.) spaced joists or studs, a simple "box" is constructed in the wall/ceiling.

Two 2x8's (to match existing 2x8 attic joists), 14½" long have been nailed in place 24" o.c. apart to form the box as shown in below. If your joists or trusses use 2x4, 2x6, 2x10, etc., please substitute the appropriate depth pieces. For 24" o.c. joists, place the cross pieces 16" o.c. apart, creating a box with inside dimensions of 14½"x22½". The illustrations on page 5 show the fans sitting on top of 2x8 joists. The joists are 16" apart on-center and have a total distance between them of 14½".

Use a stud finder to locate the joists or studs from the living space or drill pilot holes from the attic space to outline the grille opening in the drywall ceiling or wall. Cut the opening with a drywall cutter. The opening should be 14½" x 22½".

Place the included foam tape gasket over the top of the joists, position the fan on top of the joists, and attach the unit with the wood screws (included). Do not over tighten the screws, since this may reduce the vibration isolation qualities of the foam gasket.

Use a good quality latex caulk to seal all wood-to-wood and wood-to-metal joints to create an air-tight enclosure. This is important to ensure that all air drawn in by the fan will be from inside the house.

Attach the interior grille to the joists with the included white-capped grille screws.

Framing

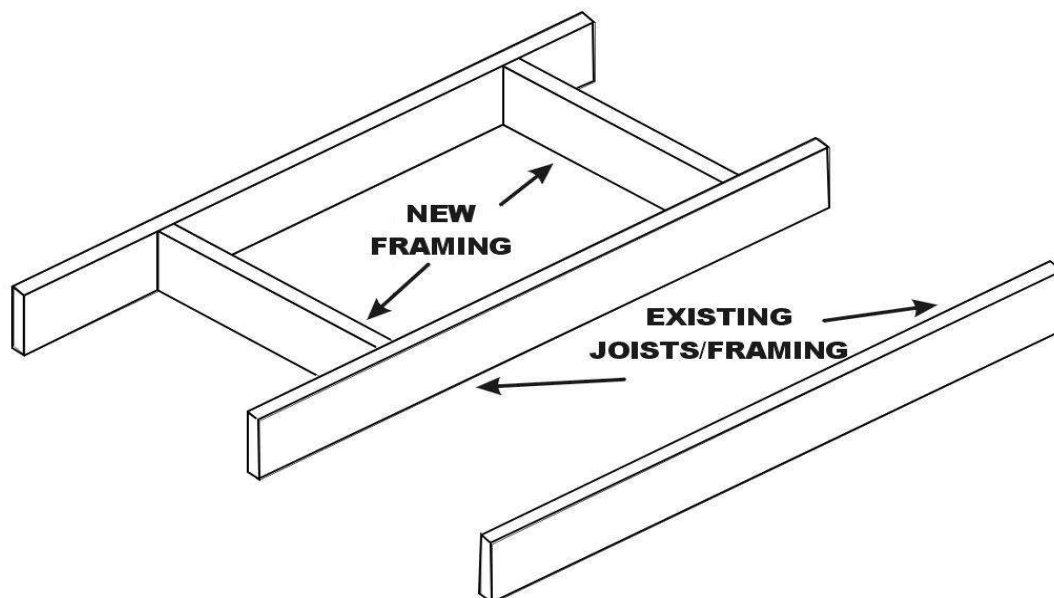

1.7 Installed (attic view)



1.0 Installed (attic view)



INSTALLATION - WALL SWITCH WIRING

Step 1: Locate the electrical box mounted on the side of the damper box. Look for a series of 5 RJ45 ports on the side of the electrical box with this label:



Step 2: Run the supplied red CAT5 cable down wall to the desired wall switch location. A 50ft cable is provided. Plug the cable into the red W/S port on the electrical box.

Step 3: Using the provided mounting bracket as a template, trace an outline on the wall where you want the wall switch located. Cut out the hole for the mounting bracket.

Step 4: Place the mounting bracket in the hole and secure with the locking tabs by tightening the silver screws.

Step 5: Connect the red CAT5 cable to the back of the wall switch and set the wall switch in place on the mounting bracket. Secure face plate to the mounting bracket using the attached face plate screws.

OPTIONAL STEPS:

WEB CONTROL

Visit our blog: blog.airscapfans.com and type “web control” into the search field. Email experts@airscapfans.com or call AirScape at 866-448-4187 for additional questions.

WIRELESS REMOTES (NOT INCLUDED) (see remote manual for complete instructions)

Step 1: Plug the blue CAT5 cable into the remote receiver and into the blue RMT port on the electrical box. Remove the top cover of the remote receiver.

Step 2: Press and release the black button on the receiver to begin the merge sequence. The transmission LED on the receiver will illuminate.

Step 3: Press and release any button on the wireless transmitter while the LED is illuminated.

Step 4: Repeat steps 2 and 3 for any additional transmitters.

Wiring Diagram

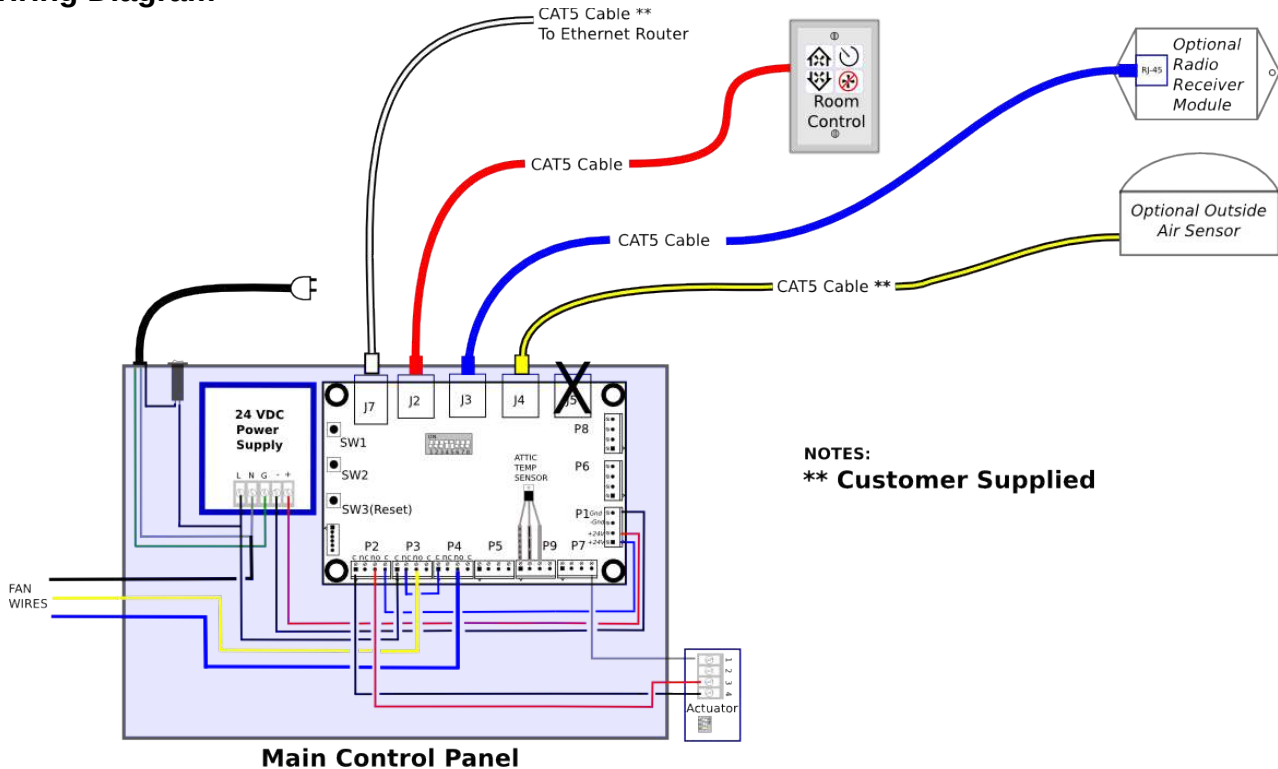

START UP AND OPERATION

- A dedicated circuit for this unit is **NOT REQUIRED**, but the power requirements of **120 volts, 1 amp (for the 1.0 model)** and **120 volts, 2 amp (for the 1.7 model)** must be taken into account when allocating power from existing electrical circuits.
- Make sure that all wiring and connections have been made per this manual and acceptable wiring standards and that no tools or construction debris have been left on, inside, or around the whole house fan. Plug the power cord into a 120v grounded outlet.
- Turn the unit ON using the arrow up button on the wall switch control. The damper doors will open and there will be a 10 second delay before the fans turn on. Once the fans start running in low speed, press the up button again to change to high speed to verify that the unit runs in both speeds. Allow for a slight delay when changing speeds for the fans to adjust speed. Use the arrow up and down buttons to change between speeds while the unit is running. Both the 1.0 WHF and the 1.7 WHF have 2 speed settings.
- Always turn the fan on using the UP button. Use the up and down arrows to change between the speeds. Turn the unit on before pressing the timer button. Press the timer button 1 time for 1 hour, up to 12 times for 12 hour operation. You can vary speeds while the timer is programmed, but turning the unit off will cancel the remaining time on timer.
- When the power is turned OFF, the fans will shut down and the damper door(s) begin to close. The door(s) will shut tightly within 60 seconds.
- For additional operating tips, maintenance information or troubleshooting tips, please see the warranty card and the Control manual.

UNIT SPECIFICATIONS

1.0 WHF

Unit Size:	27 ¼" x 17 ¼" x 7" (LxWxH) - <i>Requires at least 20" of overhead clearance for the damper door to open fully</i>
Weight:	26 lbs
Fan Energy Consumption:	39/78 watts (low/high)
Airflow:	600/1047 CFM (low/high)
Acoustical:	43/53 dBA (low/high)
Insulation:	R-14 insulated damper doors XR - R-49 insulated damper doors

1.7 WHF

Unit Size:	27" x 22" x 14" (LxWxH)
Weight:	38 lbs
Fan Energy Consumption:	78/157 watts (low/high)
Airflow:	1000/1712 CFM (low/high)
Acoustical:	44/55 dBA (low/high)
Insulation:	R-7 insulated damper doors XR - R-47 insulated damper doors

Rough Opening:	14 ½" x 22 ½"
Grille Outer Dimensions:	16 ½" x 24 ½"
Grille Build:	Aluminum with cube core center - powder coated white
Electrical:	120 VAC, 60 Hz
Speeds:	2
Installation:	Installs easily between 16" O/C joists or 24" O/C joists.
Controls:	Wall mounted hardwired timer switch, Web interface capable, Optional wireless remote
Warranty:	3 year parts warranty. 1 year controls warranty.

**Due to our continual product improvement efforts, performance ratings and specifications are subject to change without notice.*