



AirScape™

3.0 WHOLE HOUSE FAN INSTALLATION AND OPERATION GUIDE

CONGRATULATIONS on your purchase of the AirScape 3.0 Whole House Fan. This fan is designed to provide you with quiet, natural, energy-efficient cooling for many years.

Please take a few minutes to read over the sections below to make sure you are prepared for the installation. The building owner/occupant should read the section "Choosing a Location" below so that the 3.0 WHF will be correctly located to maximize effectiveness and efficiency of operation.

If you (or your installer) have any questions regarding the installation, operation, or maintenance, please see AirScape technical support at www.airscapefans.com or call 1.866.448.4187.

WHAT'S IN THE BOX

Prior to beginning installation, please verify that you received all the accessories with the whole house fan. The packages should include:

- fan assembly
- damper door enclosure with grille
- special insulated acoustical connection duct
- dual speed switch and plate
- cable ties
- duct tape
- screws
- installation instructions

THEORY OF OPERATION

Before you get started with installation, it's important to understand how your AirScape works so you can make the best installation choices and get the most out of your new equipment.

Through the length of a summer day, a large amount of heat accumulates in the structure of your home. This heat buildup can take a long time to dissipate (just feel the bricks on your house long after

sunset) and can keep your A/C working overtime well into the night, even when evening air has cooled off. Your new AirScape fan is designed to quietly and economically drain this heat from your building using freely available outdoor air rather than expensively conditioned air, and, at the same time, cool the ambient air and the occupants of the home with fresh night breezes.

Evening cooling with a whole house fan is not a new idea, however AirScape is a new type of whole house fan. While the traditional whole house fan is big, noisy and inefficient, the AirScape 3.0 is designed to be whisper quiet while still delivering enough airflow to effectively cool houses as large as 4500 sq. ft. And it's designed to work on a different operating principle.

Traditional whole house fans use massive airflow to create a very fast air change and an immediate cooling effect by generating a noticeable indoor breeze. While this can be immediately gratifying, the problem is that excessive noise and intrusiveness makes them hard to live with, so they typically are not run for extended periods of time. And that's the problem. If you turn it off, indoor air temperature shoots back up because there is still lots of retained heat in the building itself. Only continuous and prolonged airflow can drain this heat off. And that's what your AirScape unit will do -- quietly and efficiently.

So keep in mind that your AirScape fan is NOT designed to provide instant "spot-cooling" by creating strong indoor breezes. Rather, it is designed to deliver optimal airflow for a prolonged, quiet cooling cycle. When used properly, this is VERY effective for both comfort and energy savings, but it does take a little longer for occupants to feel the effects of the initial air change.

Important Operating Tips

- Only use it when the outdoor air is cooler than your indoor air.
- Make sure your A/C is off when you run the fan or you'll be blowing expensive conditioned air right out of your house!
- We recommend running your AirScape all night long. Here's why: The goal is to cool your entire house down, not just the air. It takes time to pull the heat out of the sheetrock, structure and contents of a house. By ventilating all through the night, the house starts the next day thoroughly cooled so you can delay or eliminate running energy consuming air conditioning the next day. AirScape Whole House Fans are very energy efficient so running on low speed through the night costs just pennies.
- Use high speed to quickly cool down the house and low speed to run quietly through the night.
- Never operate the unit without opening a window – this can create negative pressure in the house and cause dangerous backdrafting with gas appliances.
- You can control where the cooling effect is focused by which windows you open. Just visualize the path the air will take between the open windows and the unit. Generally, the longer the path, the more cooling effect.
- If your home has a basement, extra cooling effect can be achieved by drawing air in through the basement windows

CHOOSING A LOCATION

The diagram below (Figure 1) illustrates how cool air enters an open window and replaces hot air that is exhausted by the 3.0 WHF into the attic.

FIGURE 1

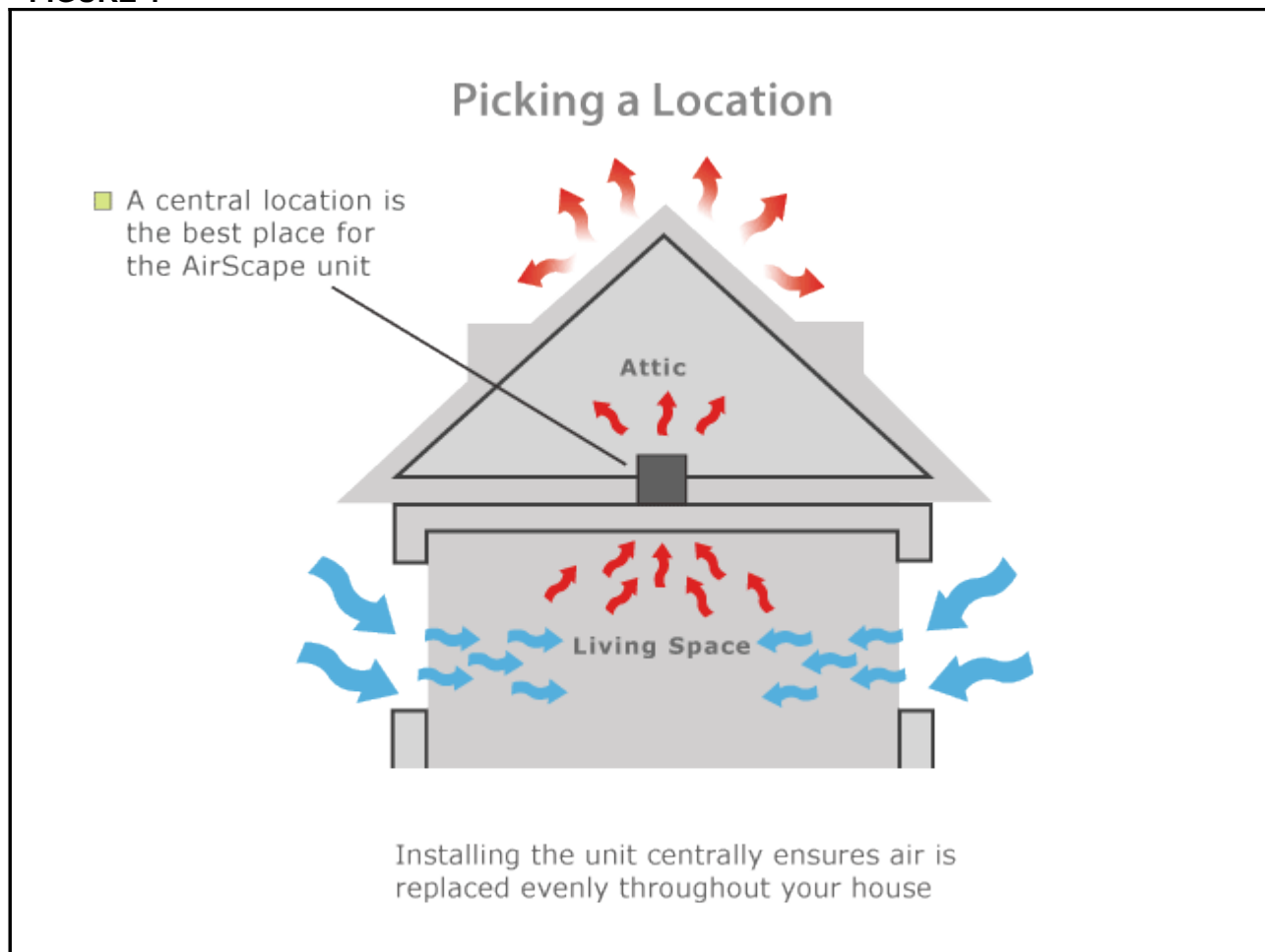

Guidelines for locating your whole house fan

- AWAY from windows that will be opened so cool air is required to travel a long path to the fan, providing maximum benefit
- At the highest point possible to exploit natural convective action
- Close to an outlet or power supply to minimize electrical work
- Typically, the ideal location in a two-story home is in the open area at the top of the stairs
- Try avoid narrow spaces close to bedrooms, as this could amplify noise at night (when noise perception is strongest)

Ceiling or Wall?

The 3.0 WHF intake box can be mounted in the horizontal or vertical orientation. Our recommended location is on a ceiling in the horizontal orientation -- keep in mind that it makes sense to place the unit high to eliminate the hottest air.

REQUIRED VENTING AREA

For proper operation of your AirScape unit, it is CRITICAL that your attic have sufficient venting area; otherwise the hot air cannot easily escape and creates back-pressure that can substantially reduce the performance of your new whole house fan. The AirScape 3.0 requires a MINIMUM of SIX square feet of "net free" venting area in your attic to allow for proper exhaust. This means that it requires the equivalent of a 3 ft by 2 ft unobstructed hole. Since most attics have multiple vents, often of different types, and since most vents are partially obstructed by louvers and/or bug/animal screens, you'll need to do some calculations to make sure your venting is sufficient. While it is our experience that most properly constructed houses have the required venting, not all do. And because this is so critical to the proper operation of your unit, it is important that you verify it.

Different types of vent designs have different ratios of obstruction caused by louvers and screening and manufacturers typically publish these numbers. If this information is not available to you, a ratio of 50% is a good rule of thumb. For example a typical 24" x 24" louver, with a gross area of 4 sq. ft. would have a net free area of 2 sq. ft.

Vent Type	Length	Width	Net Free Area (NFA%)	Calculation L x W x NFA / 144
Louver	16"	16"	50 %	= 16 x 16 x 0.5 /144 = 0.89 sq ft
Ridge Vent	48"	not used	13 %	= 48 x0.13 /12 = 0.52 sq ft
Eave Vent	12"	4"	50 %	= 12 x 4 x 0.5 /144 = 0.16 sq ft

UNIT PARTS & DIMENSIONS

FIGURE 2 – Parts & Dimensions.

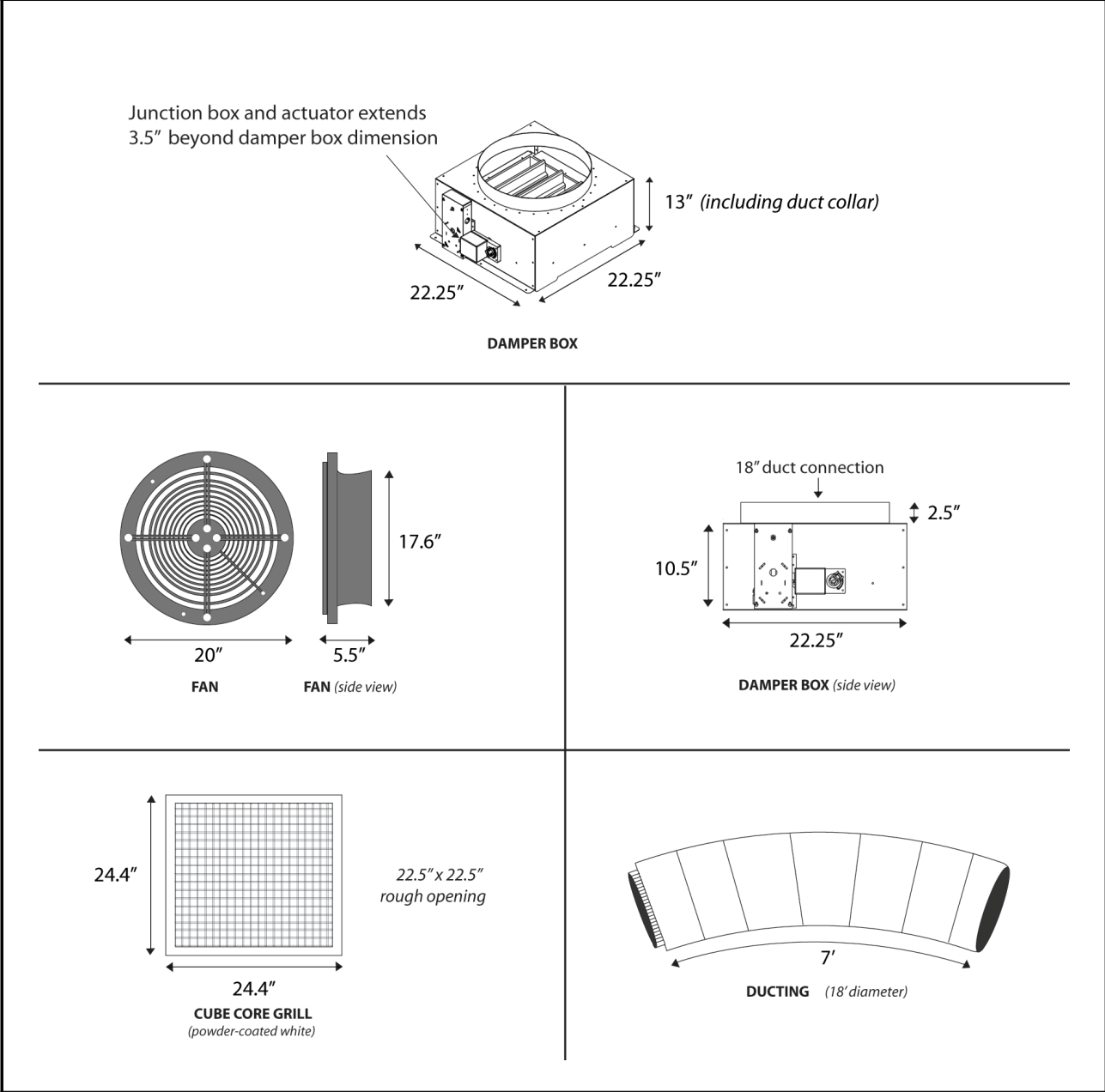

INSTALLATION - CARPENTRY

The 3.0 WHF has been designed to fit a 22½" x 22½" wall or ceiling opening, which corresponds to 24" on-center (O.C.) framing. With a few extra steps, the 3.0 WHF can be installed in situations with 16" O.C. framing.

The first step is to construct a simple "box" with inside dimensions of 22½" x 22½". The 3.0 WHF damper enclosure can be mounted in any orientation, so the following directions can apply to both ceiling and wall mounting.

For 24" on-center framing:

The illustration below (Figure 3) shows the damper enclosure sitting on top of 2"x8" joists. The joists are 24" on-center and have a net space between them of 22½". Two 2x8's, 22½" long have been nailed in place to form the box. If your joists or trusses use 2" x "another depth", please substitute the appropriate depth pieces.

For 16" on-center framing:

The illustration below (Figure 4) shows the damper enclosure sitting on top of 2"x8" joists. The joists are 16" on-center and have a net space between them of 14½". The following 2x8's (4 qty. 14½", 1 qty. 22½" long) have been nailed in place to form the box (If your joists or trusses use 2" x "another depth", please substitute the appropriate depth pieces). Note that you will end up with a box with inside dimensions of 22½" x 22½" with a joist running through it. This "extra" joist will not significantly disturb the airstream.

Next, use a stud finder to locate the studs from below or drill pilot holes from above to outline the grille opening in the drywall ceiling. Cut the opening with a drywall cutter. The opening should be 22½" x 22½".

Position the 3.0 WHF damper enclosure on top of the joists. Rotate the enclosure as required so that there is easy access to the electrical box. Attach with wood screws to the joists.

Use a good quality latex caulk to seal all wood-to-wood and wood-to-metal joints to create an air-tight enclosure. This is important to ensure that all air drawn in by the fan will be from inside the house.

Next attach the interior grille to the joists with the included white painted screws. If you have 16" O.C. framing, you may need to trim or cut a small section of the grille flange to accommodate the middle stud (see Figure 5).

FIGURE 3 – 24" O/C Framing.

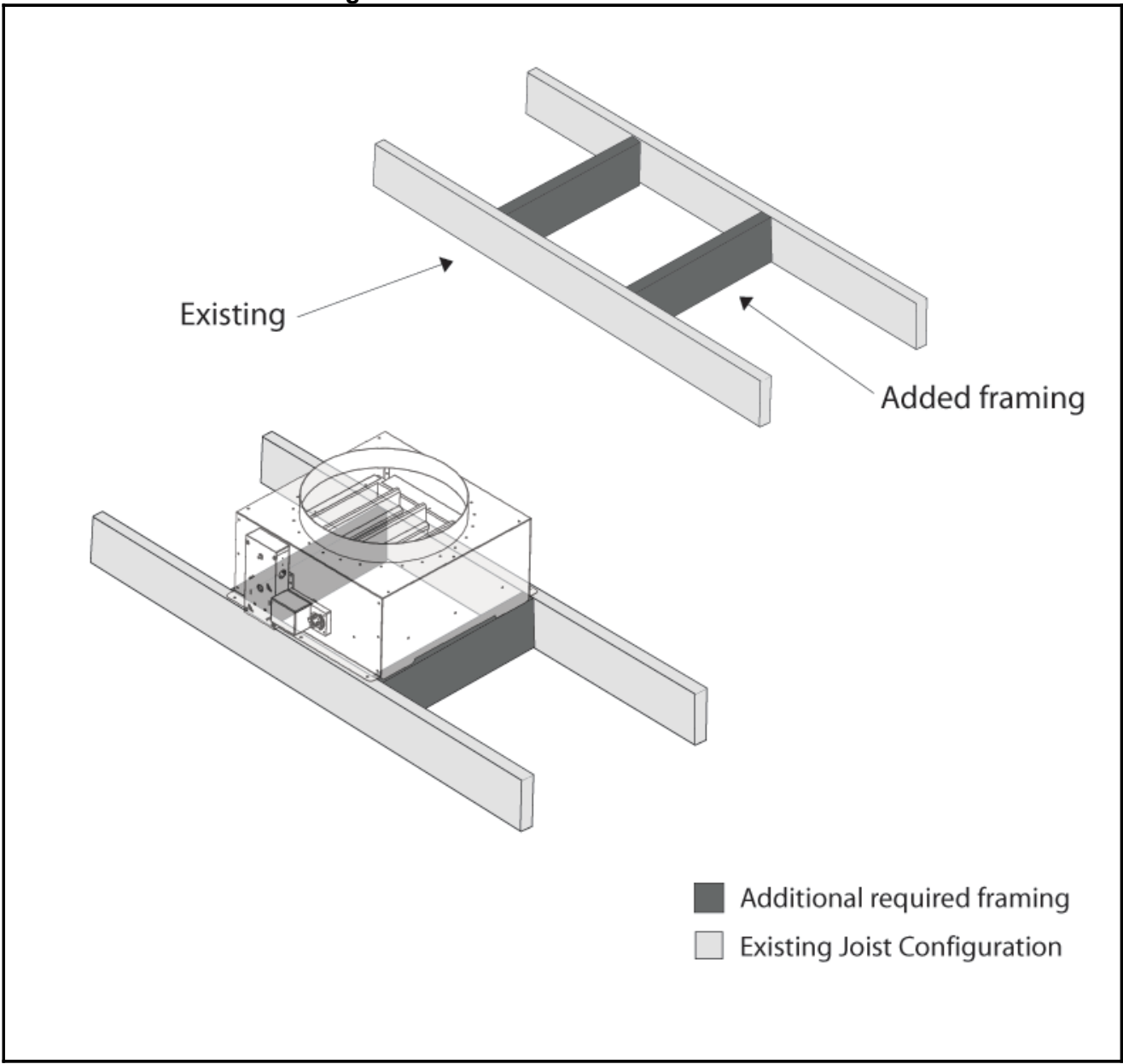

FIGURE 4 – 16” O/C Framing.

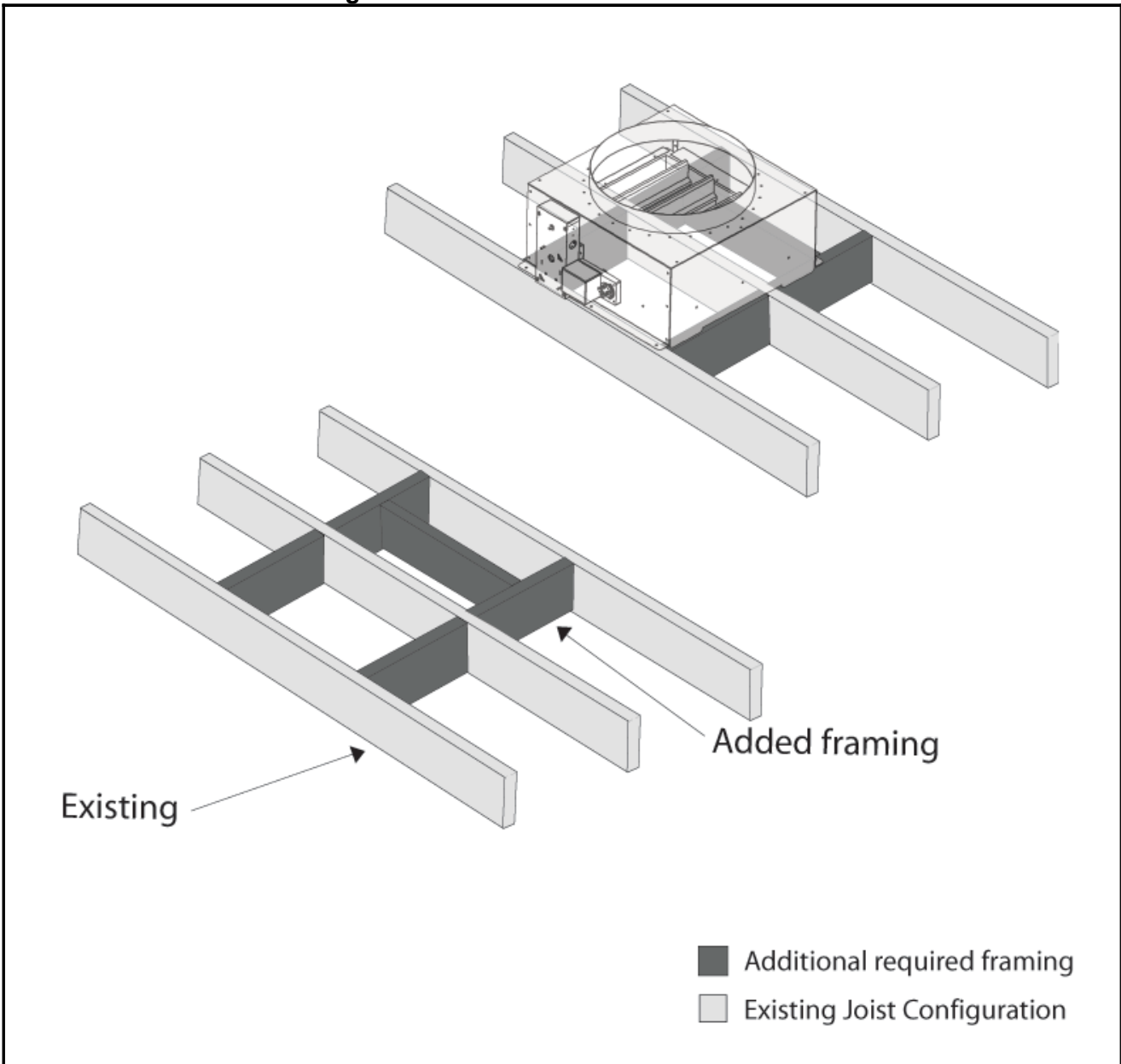
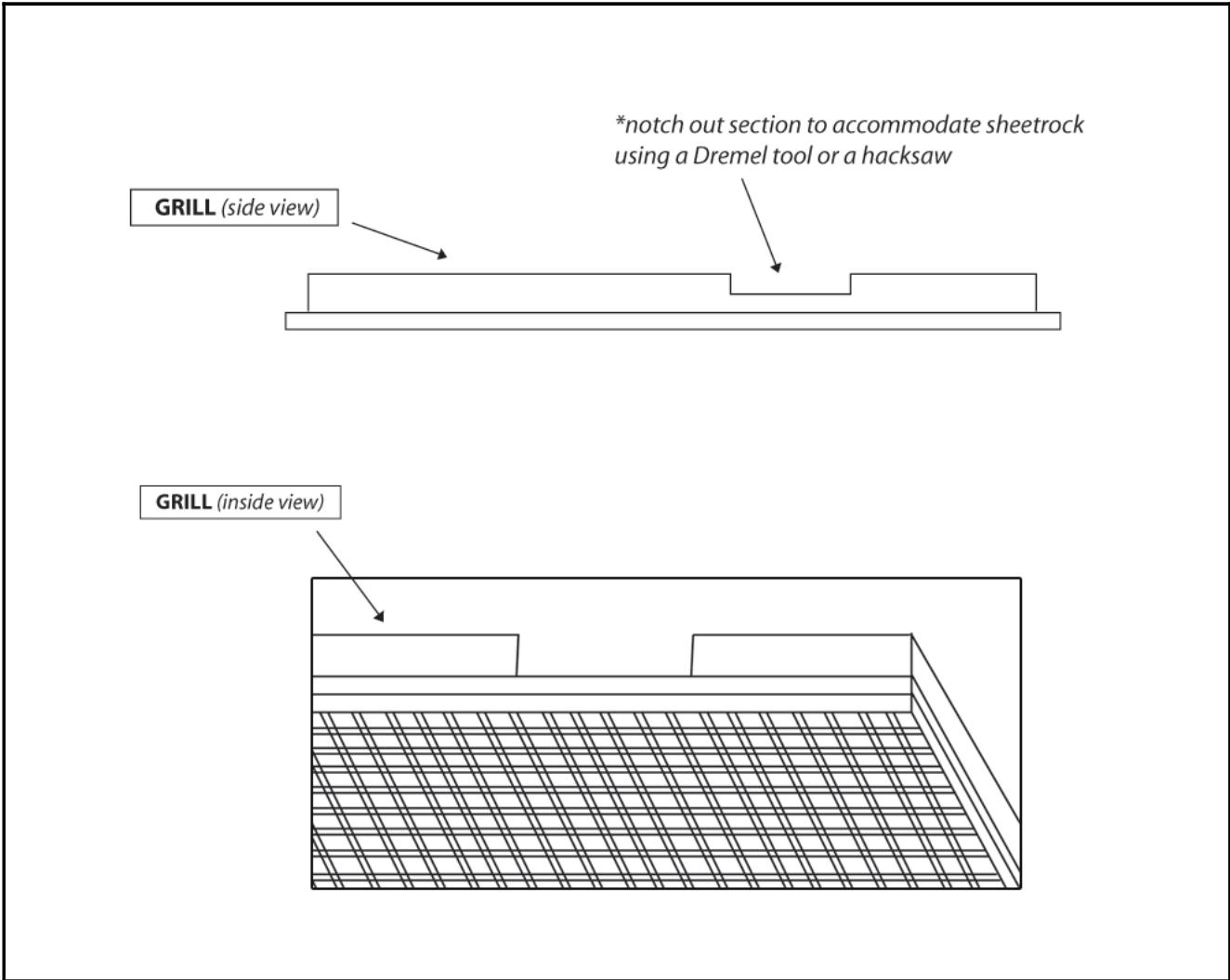

FIGURE 5 – Grille Notch -- ONLY 16" O/C Installations.



DUCT AND FAN CONNECTIONS

Attach the metal collar end of the flexible duct to the damper enclosure by sliding the duct collar over the damper box duct collar (see figure 6). Secure the connection by first using the self-drilling sheet metal screws and then seal the joint with the included duct tape.

At the other end (no duct collar) push the foil outer liner and insulation back to expose the inner duct liner. Secure the inner duct liner to the fan flange by first using 2 tie wraps (attach together to make circumference) cinched down (see figure 7). Wrap the joint with duct tape, then pull the insulation and foil liner over the joint and secure with duct tape as well.

FIGURE 6 – Duct to Damper Enclosure Connection.

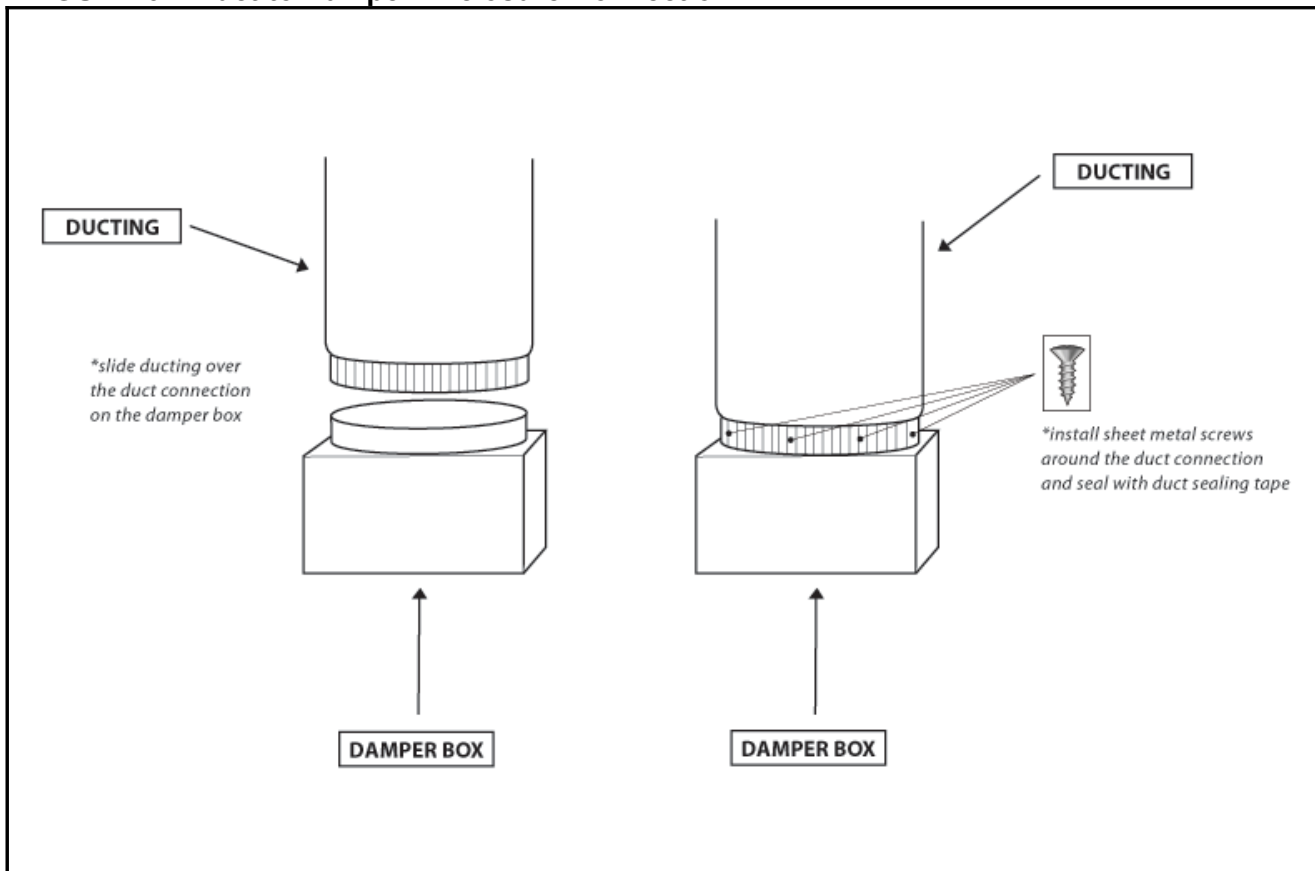
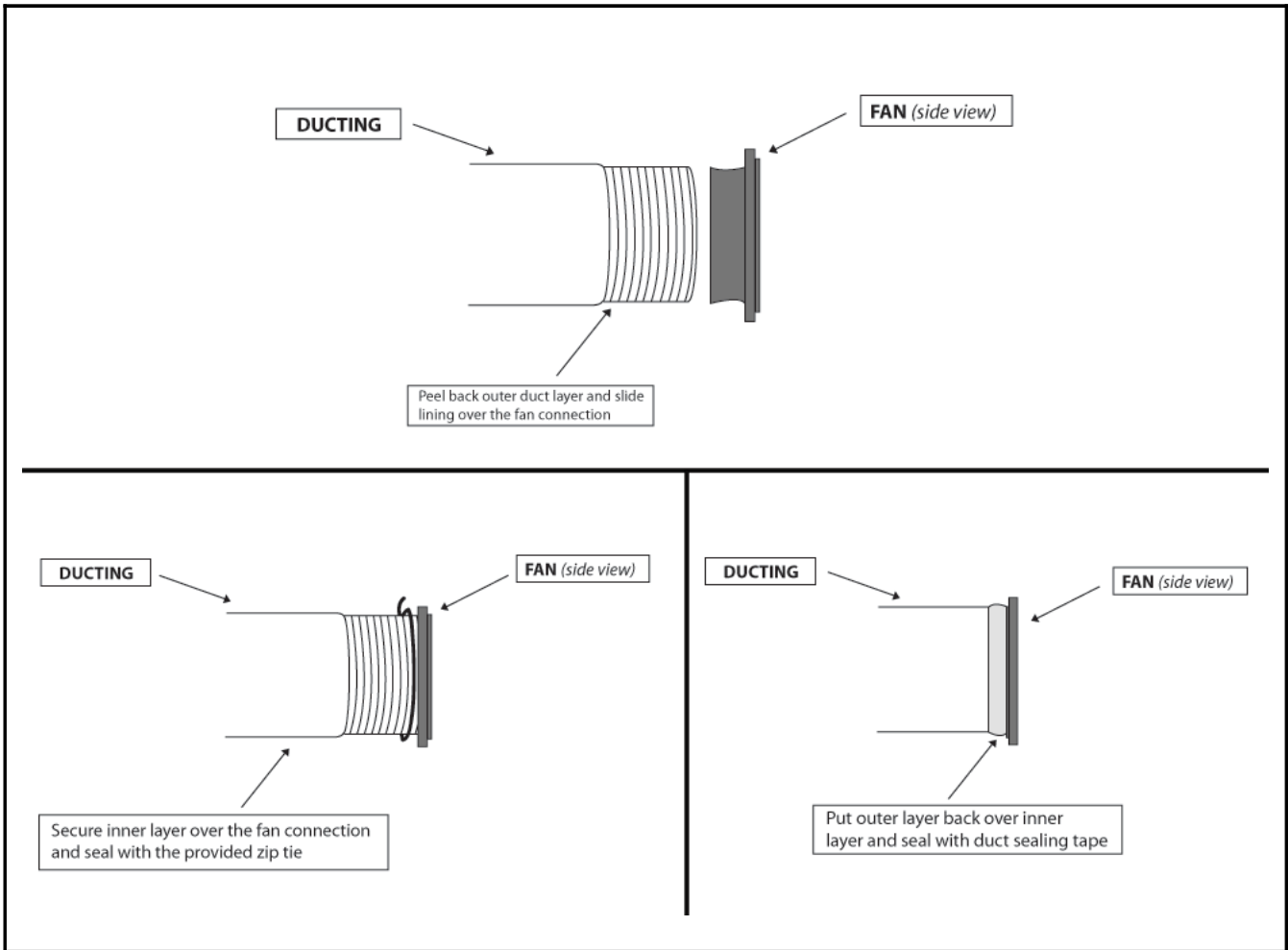

FIGURE 7 – Duct to Fan Connection.



Use a section of the included chain to hang the fan by one of its eyelets. The duct should be gently bent 90 degrees for maximum sound attenuation. Two other sections of chain should be used to secure the fan from any swaying motion (see figure 8).

Avoid sharp bends in the duct or contact with metal fixtures, pipes, or conduits. The duct section immediately before the fan should be as straight as possible to ensure smooth airflow to the fan.

FIGURE 8 – Installation View.

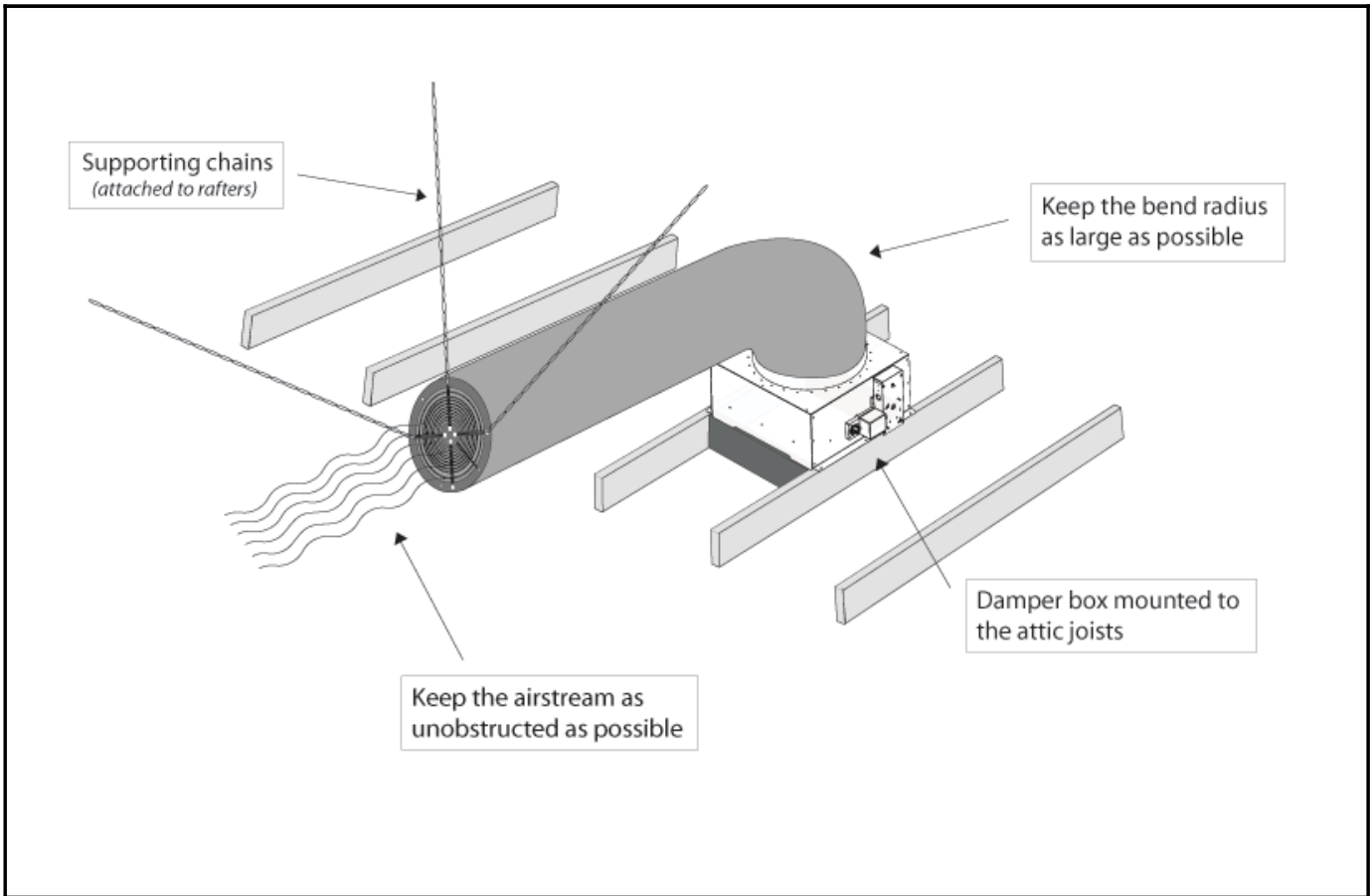

INSTALLATION – WIRING (HARDWIRED SWITCH)



The instructions below correspond to 3.0 WHF units manufactured after April 2008 with 24 VDC circuit boards. All other unit units require different instructions.

The easiest way to wire the 3.0 WHF is as follows (see Figure 9).

Step 1: Run a 3-wire cable 18 gauge or thicker for the 24 VDC low-voltage wiring from the damper enclosure to the wall-mounted double switch provided with the unit. This 3-wire cable is NOT supplied with the unit but is widely available (thermostat cable is acceptable). Connect the control wiring to the switch and unit circuit board as shown in figure 9 below. Once the connections are made, secure the faceplate.

Step 2: Plug-in the fan control cord to the female socket on the damper enclosure electrical box.

Step 3: When ready, plug-in the main power cord into a 120-volt outlet. Alternatively, if you want to hardwire the unit, remove the main power cord and provide 120-volt power to the damper enclosure electrical box. Connect power to the circuit board inside the control box (see figure 10).

The control wall switch must be mounted in an approved electrical box large enough to accommodate the entering wires. Use approved methods such as wire nuts to connect wire ends.

General wiring notes:

- Local codes and standards must be followed in the installation of this unit.
- A dedicated circuit for this unit is not required, however the running power requirements of 120 volts, 3 amps must be taken into account when allocating power from existing electrical circuits.

FIGURE 9 – Wiring with hardwired switch and power cord.

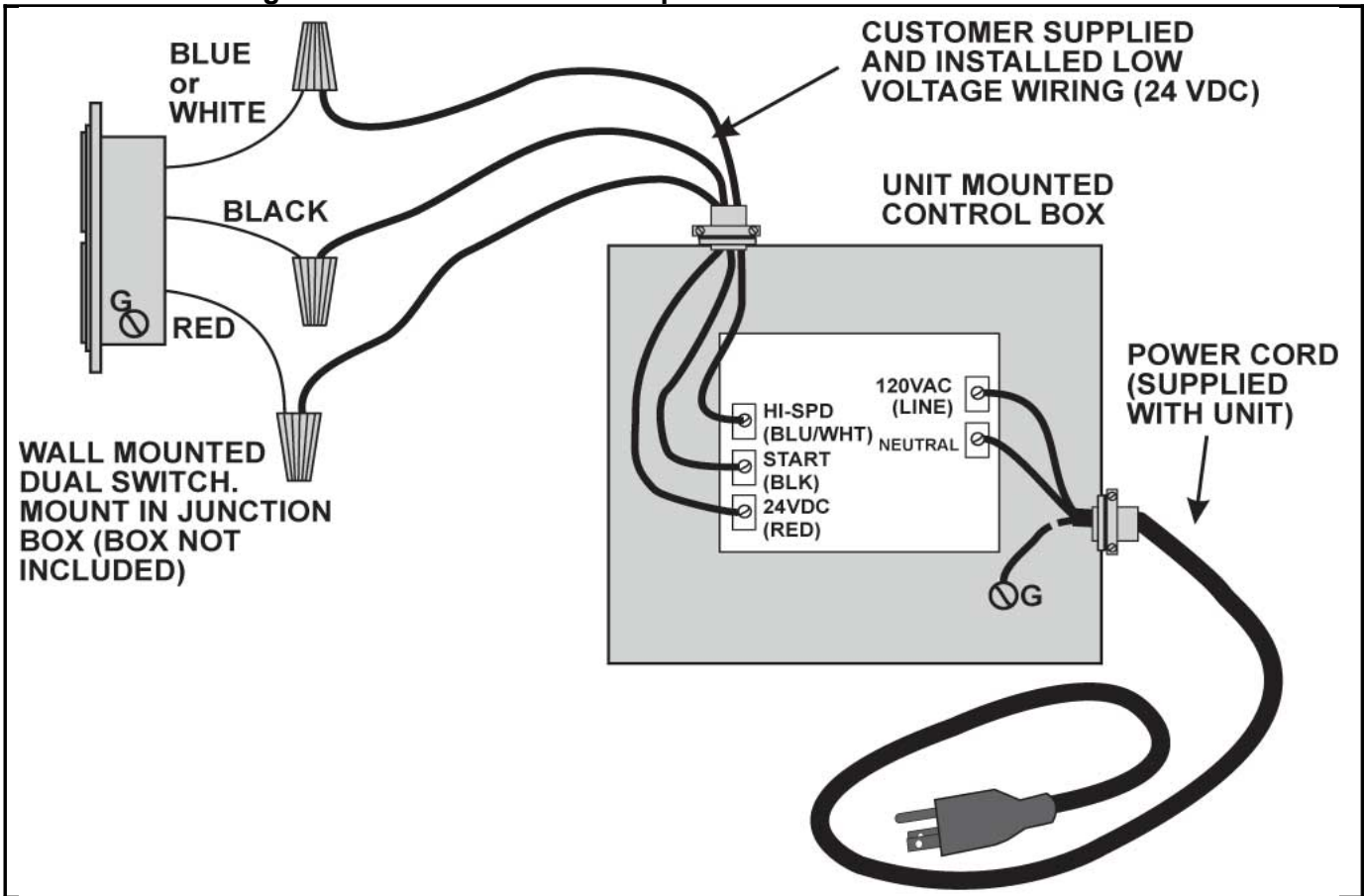
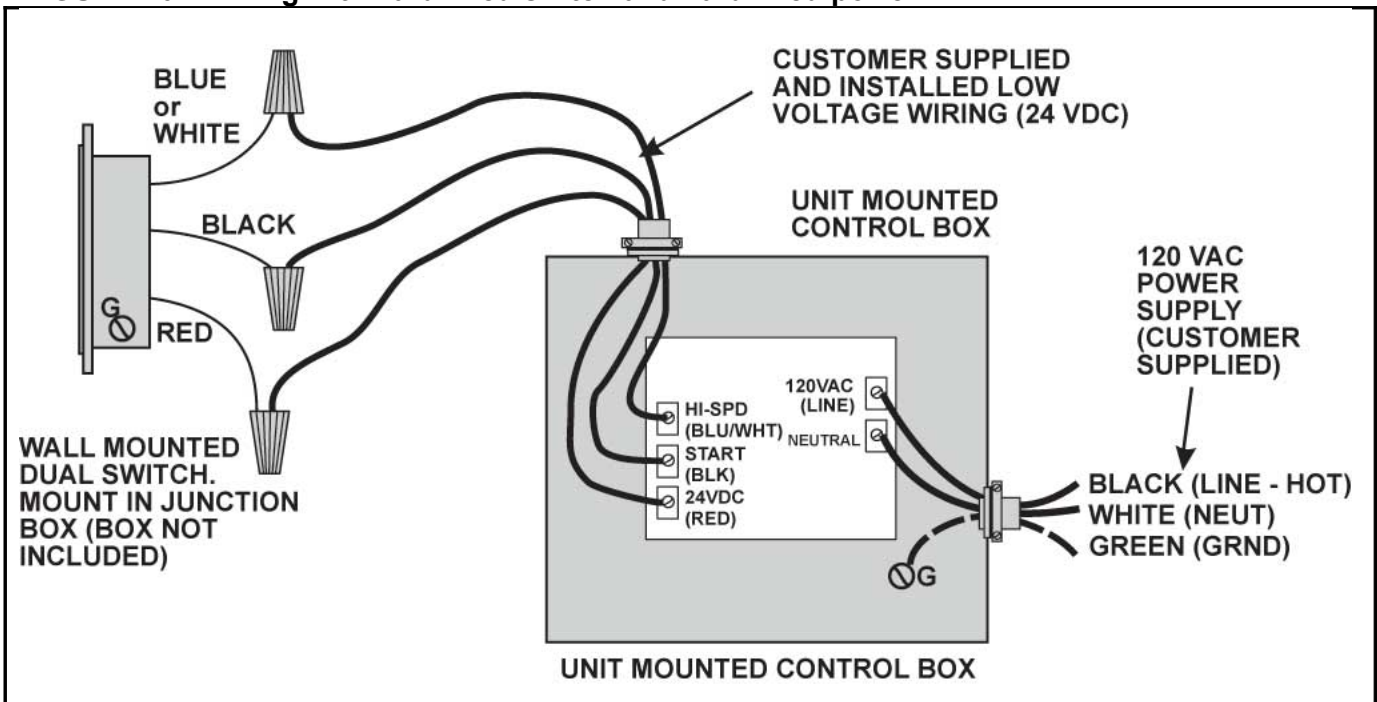

FIGURE 10 – Wiring with hardwired switch and hardwired power.



INSTALLATION – WIRING (OPTIONAL REMOTE CONTROL)



The instructions below correspond to 3.0 WHF units manufactured after April 2008 with 24 VDC circuit boards. All other unit units require different instructions.

Figure 11 below shows wiring for the optional wireless remote control unit (not included).

Step 1: Remove the faceplate from the WHF electrical box. Remove the electrical knockout on faceplate and install the nylon insert. Route the black and white power wires that are on the back of the module through the nylon insert. Position the module onto the faceplate so that it is seated in between the mounting guides and pushed completely down onto the plate. Note that there will be a gap between the module and the faceplate. Install the module retaining bracket by sliding it down over the module (be careful not to damage wires), inserting bracket ends into small slots on electrical box faceplate. Make sure tabs on bracket snap completely into slots to lock module into place.

Step 2: Connect the 120-volt power wires (back of receiver) from the remote control receiver to the 120VAC(LINE) and NEUTRAL contacts on the circuit board as shown in figure 11.

Step 3: Connect the 24 VDC low-voltage wiring to the circuit board of the unit from the remote control receiver as shown in figure 11.

Step 4: Plug-in the fan control cord to the female socket on the damper enclosure electrical box.

Step 5: When ready, plug-in the main power cord into a 120-volt outlet. Alternatively, if you want to hardwire the unit, remove the power cord and provide 120-volt power to the damper enclosure electrical box. Connect power to the circuit board inside the control box.

Step 6: See programming and security code information below and on the sheet included with the optional remote package for additional operation information.

General wiring notes:

- Local codes and standards must be followed in the installation of this unit.
- As noted in the diagram, use approved methods such as wire nuts to connect wire ends.
- A dedicated circuit for this unit is not required, however the running power requirements of 120 volts, 3 amps must be taken into account when allocating power from existing electrical circuits.

FIGURE 11 – Wiring optional remote control unit – Power AND control wiring shown

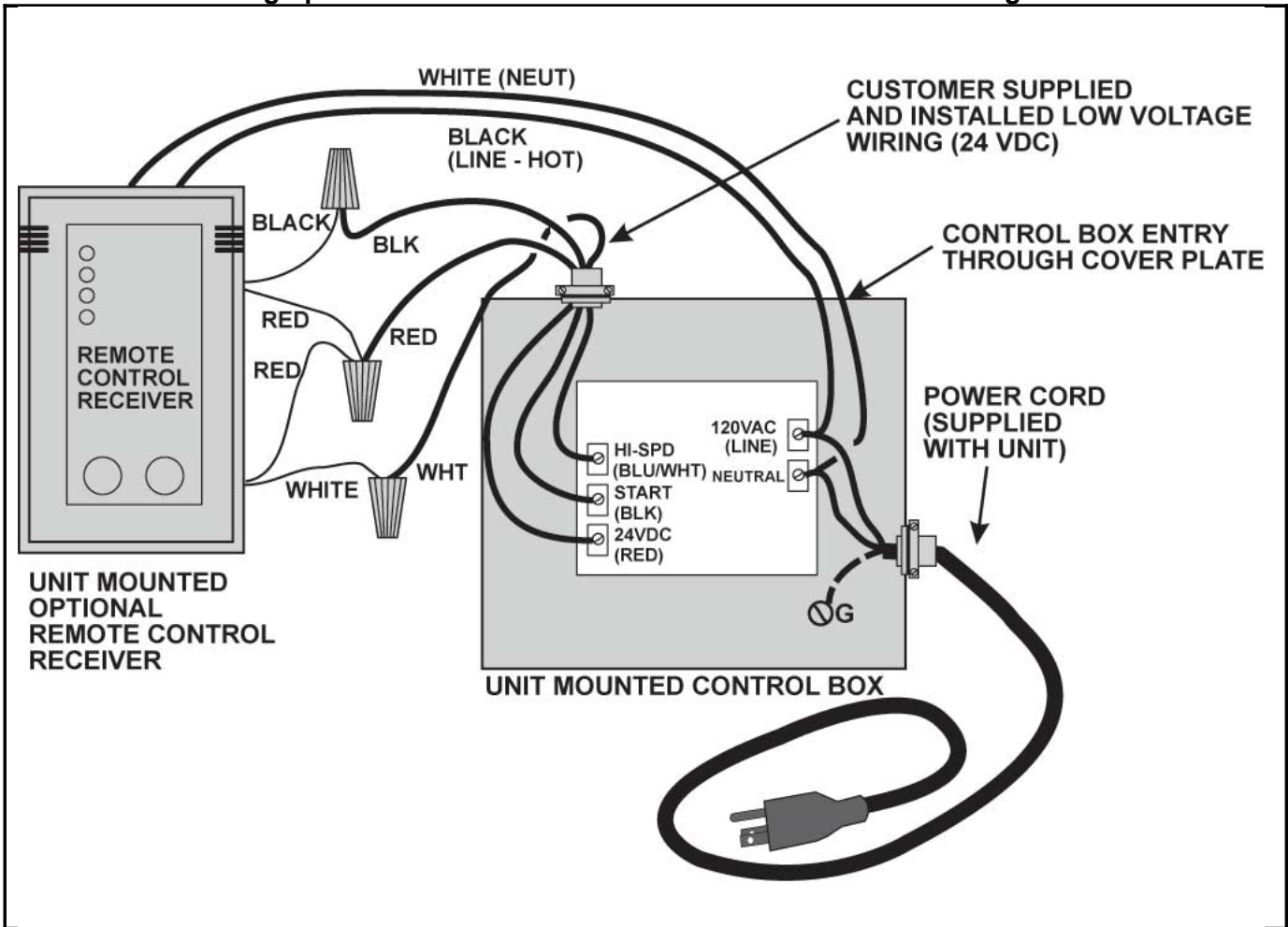

FIGURE 12 – Optional Remote Receiver Retaining Bracket.

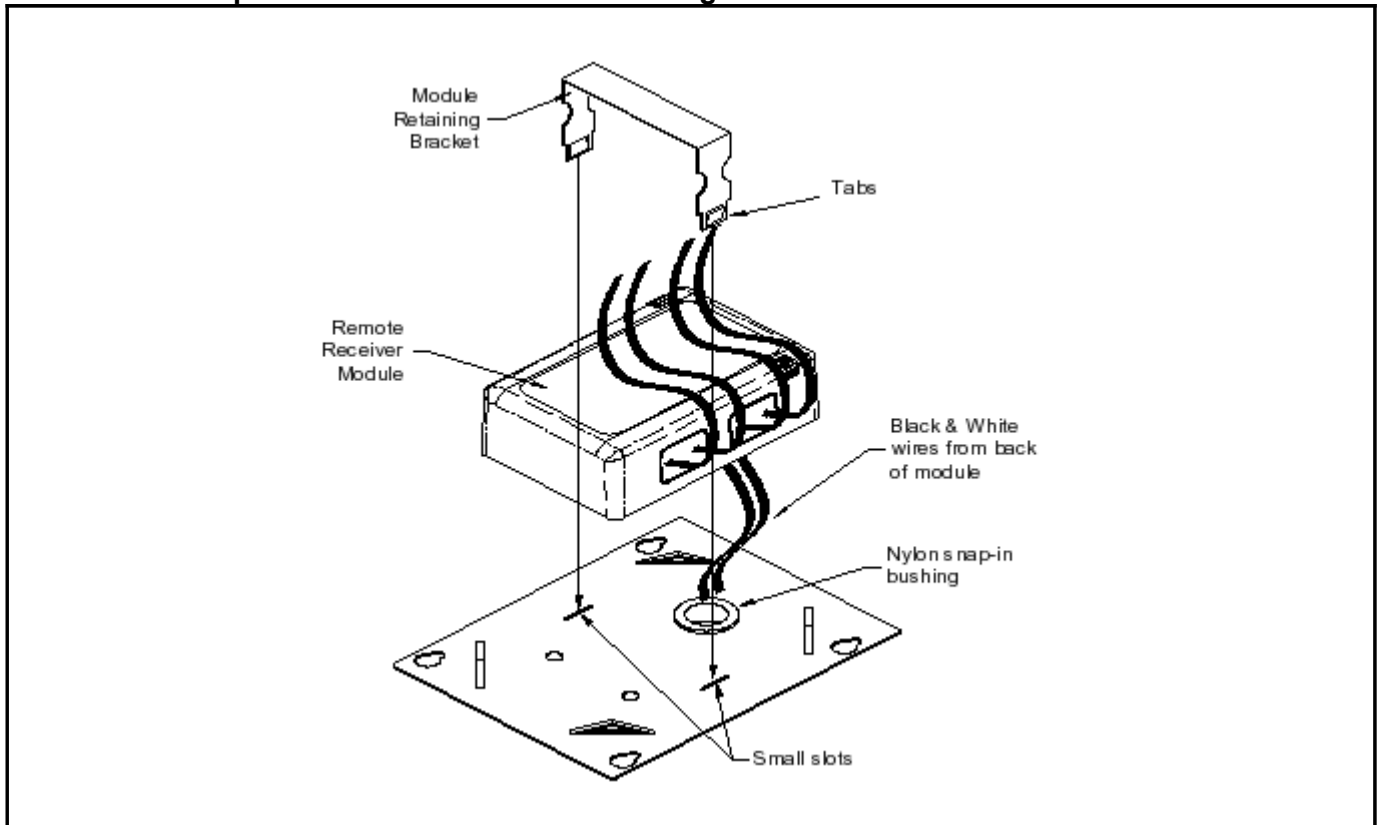

FIGURE 13 – Optional Remote Control Receiver.

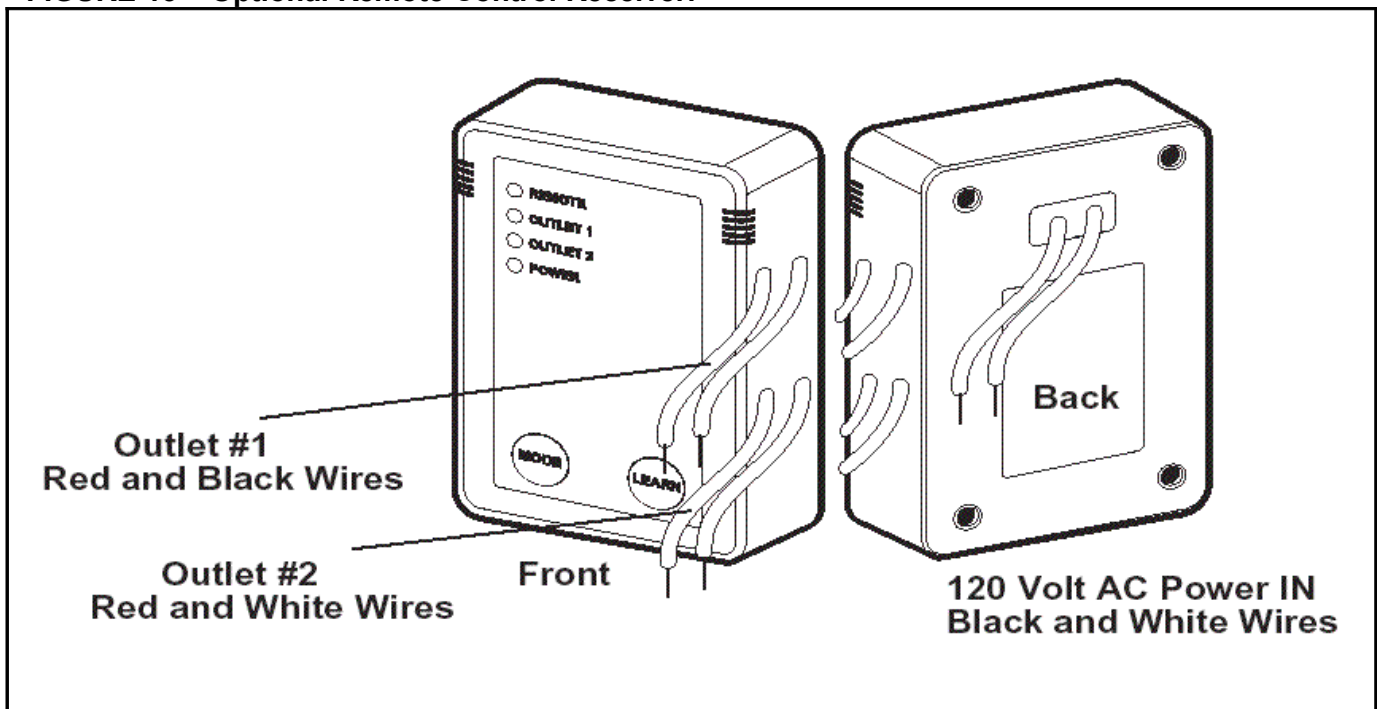
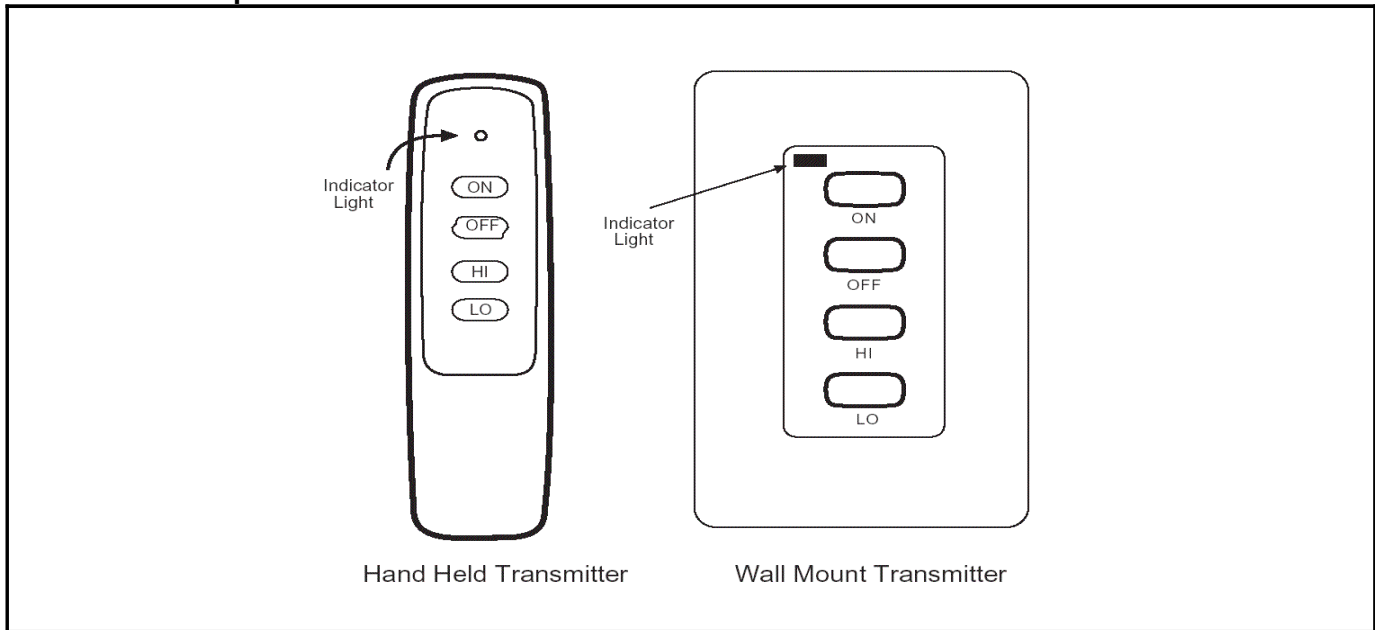

FIGURE 14 – Optional Remote Control Transmitter.



Matching security codes on the receiver:

It may be necessary to program the remote receiver to LEARN the security code of the transmitter upon initial use or if battery is replaced. To program the remote receiver to LEARN a new security code of the transmitter:

1. Push and release the LEARN button (do not hold) on the receiver. When you hear the faint “Beep”, press and hold the ON or OFF button for about 2 to 3 seconds on the transmitter. A confirming series of faint “Beeps” will come from the receiver to indicate that the receiver has accepted the transmitter code. Then the receiver will operate with both transmitters.

Programming multiple transmitters to the receiver:

The Airscape receiver can hold up to 3 different transmitter codes.

1. Push and release the LEARN button (do not hold) on the receiver.
2. When you hear the faint “Beep”, press and hold the ON or OFF button for about 2 to 3 seconds on the transmitter. A confirming series of faint “Beeps” will come from the receiver to indicate that the receiver has accepted the transmitter code. Then the receiver will operate with both transmitters.

If the LEARN button is pressed and the **receiver makes NO “Beep” sounds** this indicates that the receiver is unable to accept any more transmitter codes. To clear the codes from the receiver, press and hold the LEARN button for 10 seconds. The receiver will emit a series of faint “Beeps,” indicating that the receiver has cleared all codes and is ready to accept new codes. Repeat the above steps 1-2 to enter new codes.

LOW SPEED SETTING ADJUSTMENT

The 3.0 WHF has a field adjustable low speed. You can adjust the setting to perfectly match the airflow required to cool your house at night.

To make changes, turn the unit on in low speed and rotate the speed adjustment knob on the electrical box until the desired speed is achieved.

Turning the knob clockwise decreases the low speed setting.

Do not turn the knob all the way counter-clockwise past the click stop as that will turn the unit off and disable low speed.

STARTUP AND OPERATION

- Make sure that all wiring and connections have been made per this manual and acceptable wiring standards.
- Make sure that no tools or construction debris have been left in the 3.0 WHF.
- Verify that the 3.0 WHF power switch is in the "off" position and turn on electrical power at the circuit breaker.
- Put the power switch to the "on" position, and toggle the fan speed switch, verifying that the unit runs in both high and low speed.
- When the power switch is moved to the "off" position, the fan should shut down and the damper door begin to close. The door will shut tightly within 60 seconds.

MAINTENANCE

There is no routine maintenance required for the 3.0 WHF other than to make sure that the fan blades and damper are kept clean of any possible build up of lint or other debris.

Blocking the fan discharge during operation could cause premature fan failure if internal temperatures rise to a very high level. Ensure that no items are placed within 2 feet of the fan discharge path.

TROUBLESHOOTING



Before servicing the unit, switch power off at the electrical panel to reduce the risk of electrical shock, fire, or injury.

The 3.0 WHF has been factory tested. If you have problems with the unit please take a few minutes to run through the following troubleshooting procedures before calling for assistance.

1) Symptom: Unit does not start

Possible causes: No power to unit.

Suggestion 1: Check power to the unit and wiring at both the switch and the unit mounted junction box.

Suggestion 2: Check the re-settable circuit breaker on damper enclosure electrical box.

Suggestion 2: If power is verified at the unit, remove all control wiring from the low voltage control side. Jumper 24VDC RED terminal to START (BLK). The fan should start and the damper door should open. When the jumper is removed the fan should stop and the damper should close. If the start/stop sequence checks out then there is an issue with field wiring to the switch or remote.

2) Symptom: Damper does not open

Possible causes: No power to damper actuator or damper shaft loose.

Suggestion: Check power to unit and wiring. The actuator (actuator mounted terminal block, not circuit board) should always have power to terminal 3, and terminal 2 when the fan is running (open damper). Terminal 1 should be the neutral. Verify that the actuator jaws are closed tight on the damper shaft.

3) Symptom: Unit does not run on low speed

Possible causes: Wiring issue.

Suggestion 1: Verify wiring connections to the low/high speed selector.

Suggestion 2: Verify that the low speed setting knob has not been turned counter-clockwise past the click stop which disables low speed.

4) Symptom: Unit does not run on high speed

Possible causes: Wiring issue.

Suggestion: Verify wiring connections to the low/high speed selector.

5) Symptom: Damper door opens but fan does not start

Possible causes: Wiring issue between fan and damper enclosure.

Suggestion: Verify wiring connections between fan and damper enclosure electrical box.

If you continue to have issues with the unit, or have questions about the installation and wiring, please contact AirScape technical support by email at experts@airscapefans.com or call 1-866-448-4187.

TIMECLOCKS – AUTOMATED CONTROLS

Customers may want to control the 3.0 WHF with a timeclock or other automated device. General considerations for this are:

- The device must have dry contacts (no power on contacts).
- Do not use any automated device which may repeatedly turn the fan on and off or switch speeds within a 3 minute period.
- Please consult your installer or AirScape directly if you have any questions regarding the suitability of an electric control device.

SAFETY INFORMATION



Not so obvious - Please Read:

Do not operate the 3.0 WHF without a window or door open.

This fan is meant for general ventilation. It has **NOT** been designed to vent particle laden and/or explosive mixtures of air.

LIMITED WARRANTY

AirScape warrants from the date of purchase that the product supplied by AirScape is free of defects in material and workmanship for a period of 3 years. This includes all moving parts, motors, dampers, and damper actuators.

If a failure of the product occurs, contact AirScape at 866-448-4187 and give the model number of the product, the purchase date, proof of purchase, and a description of the problem. AirScape will cover shipping charges during the first 6 months of warranty. Customer is responsible for all inbound and outbound shipping charges after the initial 6 month period.

Once a problem is diagnosed, and proof of purchase is verified, AirScape will have the option of shipping the necessary repair part(s) to the Customer or having the product returned to AirScape for repair or replacement.

If AirScape finds the returned product to be in operating condition, the product will be returned to the customer at customer's expense. AirScape reserves the right to obtain a credit card authorization for possible freight charges or non-return of defective parts/unit.

Specific warranty exclusions:

Except as provided by this express warranty, the goods are sold without any implied warranties. This limited warranty does not cover labour or field diagnosis, nor does it cover failure of the installer to follow installation instructions, damage resulting from accident, misuse or abuse, lack of maintenance, improper installation. In no event, shall AirScape be liable for any special, incidental, or consequential damages resulting from any defect in material or workmanship. It is expressly understood that Buyer's sole and exclusive remedy shall be repair or replacement of defective parts.

UNIT SPECIFICATIONS

Damper Box Size:	22.25" x 22.25"x10.5" (13" with duct collar) -- LxWxH
Duct Length:	7 feet
Duct Diameter:	18"
Rough Opening:	22.5" x 22.5"
Grille Outer Dimensions:	24.4" x 24.4"
Grille Build:	Aluminum with cube core center - powder coated white
Electrical:	115 VAC, 60 Hz
Fan Energy Consumption:	360 watts at full speed
Speeds:	2 (adjustable low speed)
Airflow - High Speed:	3050 CFM
Airflow - Low Speed:	Adjustable
Acoustical - High Speed:	Less than 2 Sones
Acoustical - Low Speed:	Depends on low speed setting
Installation:	Installs easily between 24" O/C joists. Can be installed on 16" O/C joists by straddling joist.
Operation:	Dual SPST switch (Decora style). Supplied with unit. Optional remote control available.
Insulation:	Yes - insulated damper blades
Warranty:	3 years